

J. PRATT.  
MECHANICAL TYPOGRAPHER.

No. 81,000.

Patented Aug. 11, 1868.

Fig. 1.

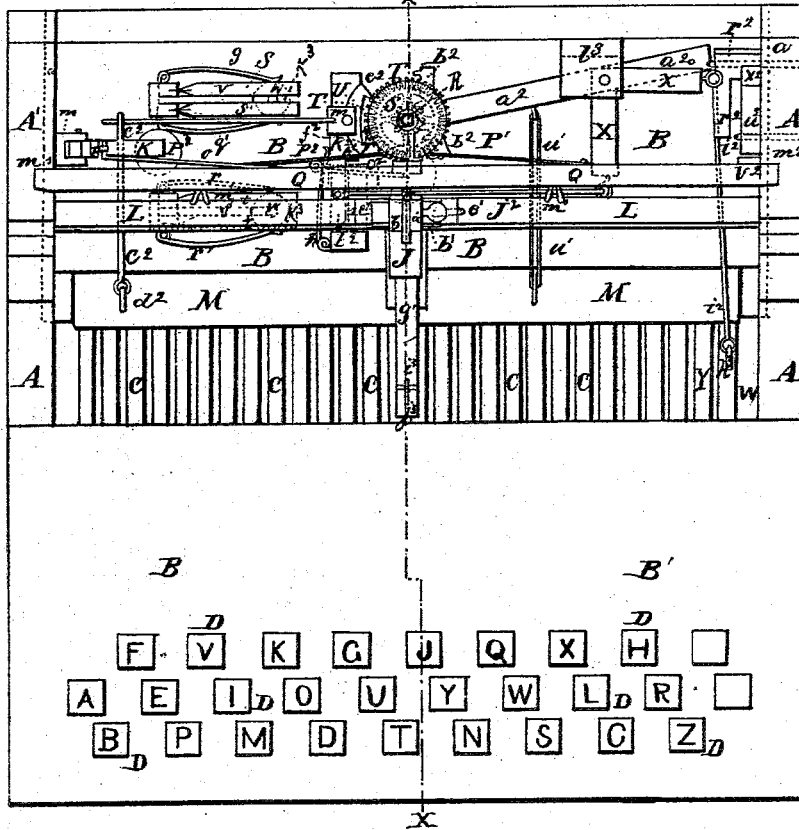

Witnesses:

*Henry Lilly*  
*George Rossetine*

Inventor:

*John Pratt*

J. PRATT.  
MECHANICAL TYPOGRAPHER.

No. 81,000.

Patented Aug. 11, 1868.

Fig. 2.

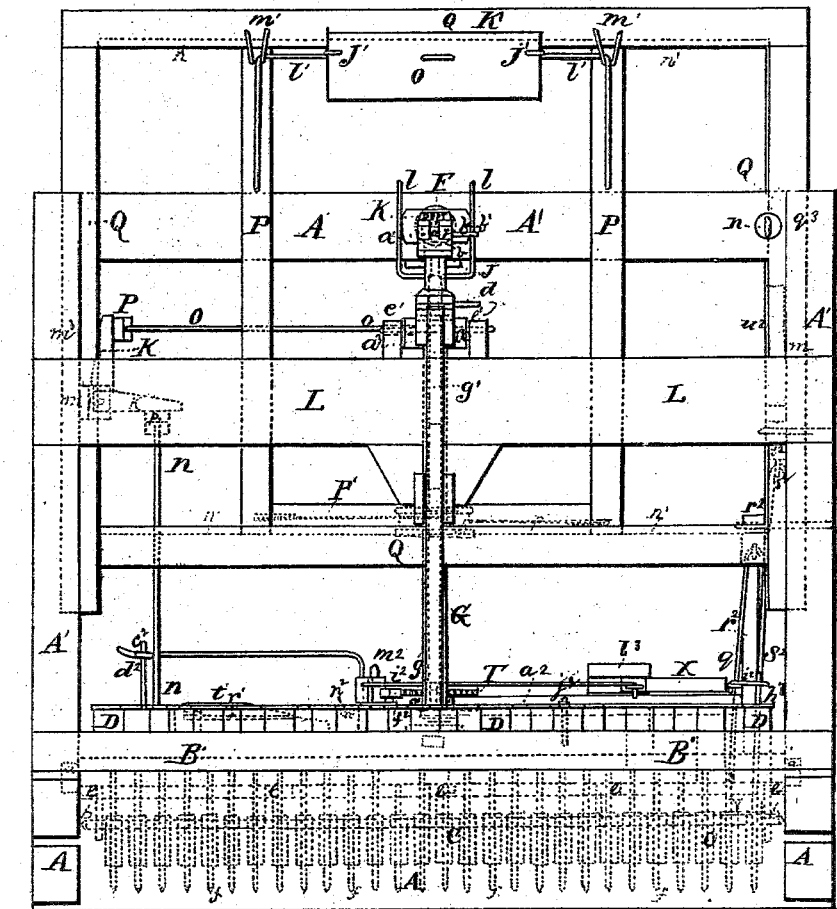

Witnesses:

*Henry Gilby*  
*George K. Sullivan*

Inventor:

*John Pratt*

J. PRATT.  
MECHANICAL TYPOGRAPHER.

No. 81,000.

Patented Aug. 11, 1868.

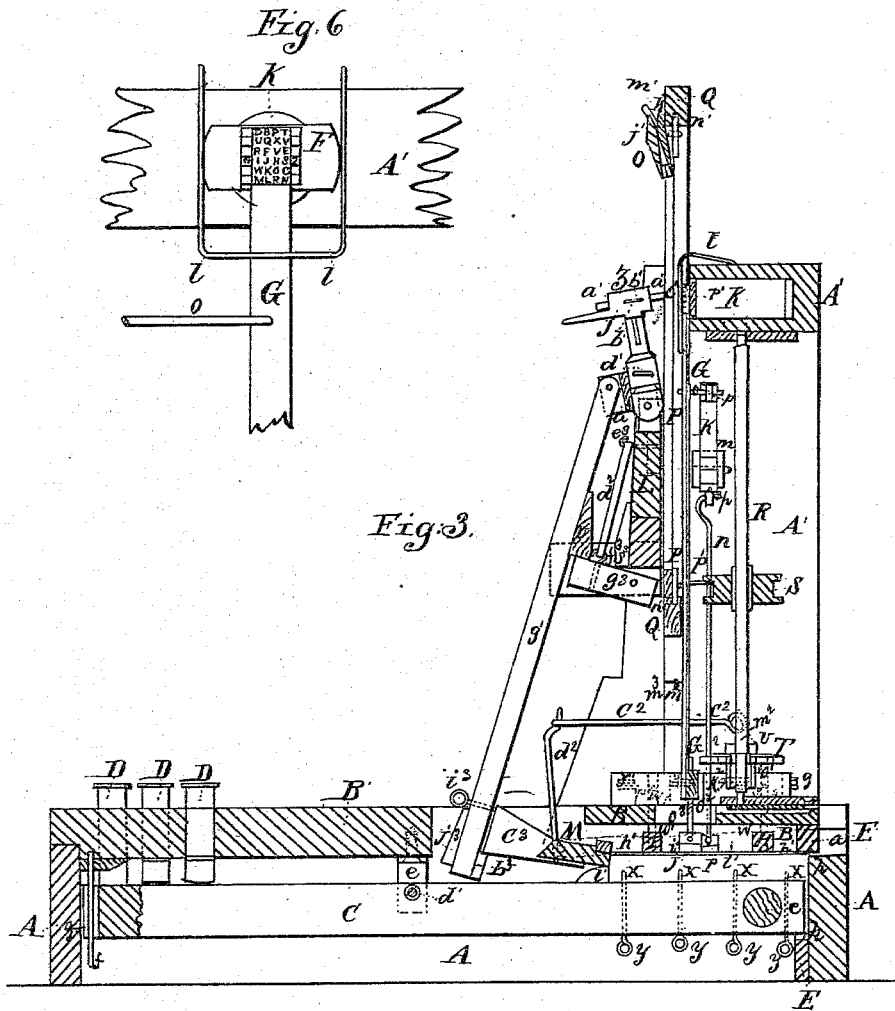

Witnesses:

Henry Pillsbury  
George Karselhaus

Inventor:

John Pratt

J. PRATT.  
MECHANICAL TYPOGRAPHER.

No. 81,000.

Patented Aug. 11, 1868.

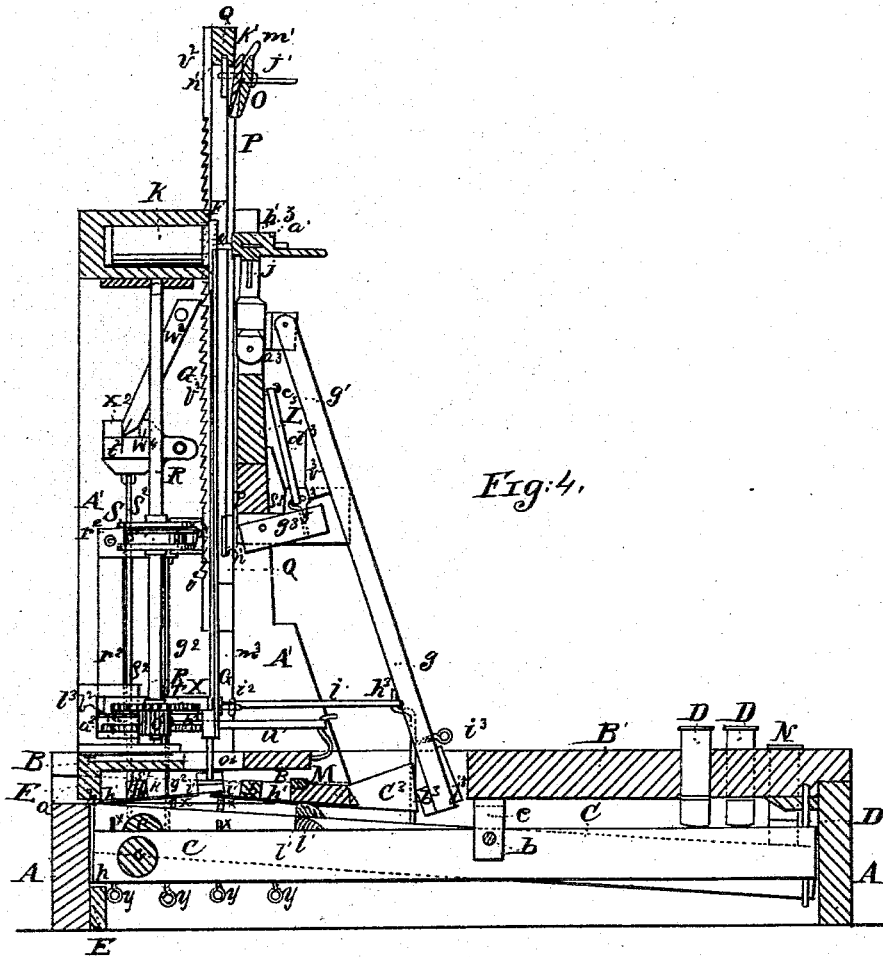

Fig. 4.

Witnesses:

Henry G. Lief  
George Haselme

Inventor:

John Pratt

Sullivan

J. PRATT.  
MECHANICAL TYPOGRAPHER.

No. 81,000.

Patented Aug. 11, 1868.

Fig. 5.

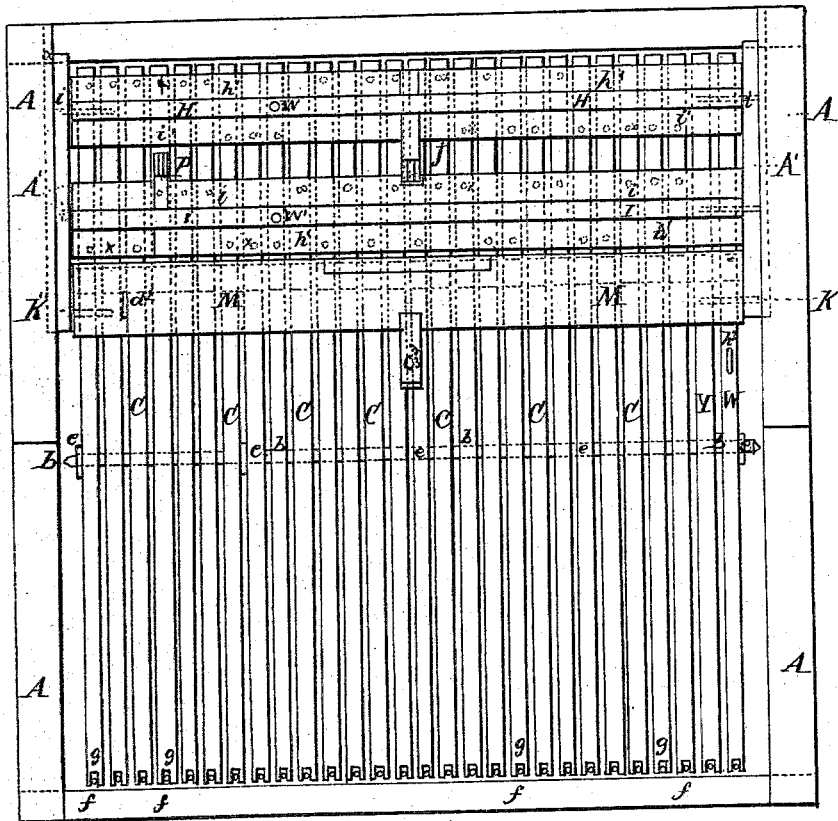

Witnesses:

Henry Pillsbury  
George Washburn

Inventor:

John Pratt

United States Patent Office.

JOHN PRATT, OF GREENVILLE, ALABAMA.

Letters Patent No. 81,000, dated August 11, 1868.

IMPROVEMENT IN MECHANICAL TYPOGRAPHERS.

The Schedule referred to in these Letters Patent and making part of the same.

TO ALL WHOM IT MAY CONCERN:

Be it known that I, JOHN PRATT, of Greenville, in the State of Alabama, have invented a new and useful Machine for Writing with Type, which I style the Pterotype; and I do hereby declare that the following is a full, clear, and exact description of the construction and operation of the same, reference being had to the annexed drawings, making a part of the specification, in which—

Figure 1 is a plan of the machine; with the top of the frame A' removed.

Figure 2 is a front elevation.

Figure 3 is a longitudinal vertical section on the line *x x*, fig. 1.

Figure 4 is a section on the line *x x*, fig. 1, showing the opposite side of the machine.

Figure 5 is a plan of the levers and oscillating-rods.

Figure 6 represents the type-plate and contiguous parts.

Three operations are requisite for a machine for writing with type; first, it is necessary to bring a number of type, in arbitrary succession, to one common point; second, to form a corresponding legible impression at that point; third, to feed or move the paper across said common point, so as to make the proper intervals between letters and words.

For those machines which do not write on an endless strip of paper, but back and forth, so as to form pages, a device is also necessary for bringing the paper back to its starting-point, and at the same time moving it in a direction at right angles with the lines, so as to make the requisite distances between said lines. These operations are performed in my machine in the following manner:

The frame A A' of the machine is constructed of wood, the part A' being secured to the part A by a tenon-and-mortise joint and screw, or by a groove, *a*, so that they may be readily separated for adjustment. B is a board extending across the lower part of the frame A', and serving as an attachment for various parts of the mechanism. B' is a key-board secured to the frame A. C is a series of wooden levers strung upon a wire, *b*, attached to the key-board in brackets, *c*. Levers C work upon cloth bearings, and may be weighted at one end with lead weights, *e*, and are preferably steadied with guide-pins, *f*, attached to the key-board, and passing through grooves, *g*, formed in their ends. Levers C are operated by keys, D, working in holes formed in the key-board, and resting upon or affixed to said levers. If affixed to the levers, they will act as guides, and the guide-pins may be dispensed with. Bars, E, faced with cloth, *h*, serve to limit the movement of the levers C. The first three operations of my machine are performed through the said keys D and levers C, the two levers Y and W, on the right hand of the machine, being employed for the fourth operation.

I will now describe how said keys and levers bring a number of type to the same point. The type are formed in relief, in parallel rows on a metal plate, F, having a tail-piece, for attachment to a vertical rod, G, operated by two oscillating-rods, H I, furnished with projections, *k*. The rods H I work in cloth-lined bearings in frame A', and extend across the frame, above the levers C, by which they are oscillated. To one of the projections, *k*, of the rod H, the vertical rod G is attached, by means of an India-rubber joint, *j*, which allows it motion in all directions. The back of the type-plate is slightly pressed by any suitable spring, *l*, against a metal bar, *k*, resting in a cloth-lined socket, which bar serves as a support for the plate while receiving the blows of the hammer J. When operated by the oscillating-rod H, said plate moves only in a vertical direction, the horizontal movement being communicated by the oscillating-rod I and bell-crank lever K. The lever K works in cloth-lined bearings in the block *m*, and is connected with the rod I by the wire link *n*, and with the rod G by the wire link *o*, said links working in India-rubber joints, *p*. The employment of the link *o* prevents the horizontal and vertical movements of rod G from interfering with each other, so that if the plate F is moved by only one of the oscillating-rods H I, its movement is horizontal or vertical, according to the lever employed. If both rods are moved at the same time, the movement of the plate is diagonal, and by varying their relative amount of movement, the direction and amount of movement of plate F vary in a corresponding ratio. This variation is effected by means of the adjusting-screws *x*, passing through levers C, and ranged under the pro-

jections  $h^1$   $i^1$  of the oscillating-rods H I. The position and adjustment of these screws in any given lever are determined by the particular character pertaining to that lever. Thus the type-plate, when stationary, having its centre opposite the point of the hammer J, the letter N, on the plate, is below and to the right of the impression-point, and must move upwards and to the left to reach it. The lever controlling N must therefore be furnished with a screw under the projection  $h^1$  of the rod H, and another screw under projection  $i^1$  of the rod I. The depression of the key N and corresponding lever causes the said screws to strike said projection, and the type-plate to move upward, and to the left, a distance determined by the projection of said screw. The necessary adjustment to give the precise direction and distance which the plate must be moved in order to bring a type to the common point, is obtained by turning the screws  $x$ , which is done by applying a key to their heads,  $y$ . The type-plate is stopped when it has reached the common point, and returned to its stationary position, when the key is released by the springs  $q$   $q^1$ ,  $r$   $r^1$ , which press the vellum-hinged tongues  $s^1$   $t^1$  against the fixed projections  $v$   $v^1$ , which projections prevent the springs from pressing against each other. The pins  $w$   $w^1$  fixed in the oscillating-rod H I, pass through holes  $k^2$  in board B, and between the said tongues, so that the movement of said rods, and therefore of the type-plate, is resisted in all directions. Instead of having an adjusting-screw under only one of the projections of the rods H I for each of the levers C, each of said levers C may have screws under both of said projections, for stopping as well as moving the said rods, which arrangement may be employed, if desired, in conjunction with the springs  $q$   $q^1$   $r$   $r^1$ .

Instead of operating both oscillating-rods H I by one of the levers C, each of said rods may be moved by a separate lever, so as to render it necessary to depress two keys to bring a given character to the common point. In this arrangement, if the characters on the type-plate are arranged in the form of a square, so that each row, vertical and lateral, shall have the same number of characters, the number of keys necessary to be employed will be only twice the square root of the number of characters. For example, if there are sixty-four characters, ranged in eight vertical and eight horizontal rows, each of the levers C will control one line, instead of one character, and the number of keys required will be only sixteen. This arrangement requires no change in the construction of the machine, but only of adjustment. For convenience, the keys D and levers C are preferably arranged in two sets, one on each side of the key-board, and the oscillating-rods H I may be placed end to end on the same line, instead of parallel to each other, and each extend only half the lateral space occupied by the levers C.

The parts immediately controlling the type-plate may also be modified in form and arrangement. The type-plate may be attached to the apex of a triangular frame, the other angles of which are attached, by means of universal joints, one to each rod H I; or it may be fixed to one end of a short radial rod, the other end of which is attached to frame A' by a universal joint, and giving to said plate a limited movement in any direction in a spherical plane, the said rod being moved by a system of links and levers similar to that already described.

My machine is equally applicable to stenographic characters as to those in common use. For stenographic characters, a single relief figure may be employed, of such a form that, by bringing any part of said form to the common point, a great variety of characters may be produced. I employ for my stenographic plate a figure of this  or any equivalent form, which, being moved to various distances, and in different directions, gives a corresponding number of characters; as, for example, T - I L L &c. By adding a figure or figures of any equivalent shape, as  $\perp$ , the number of characters may be multiplied at will.

To produce a legible impression, I employ a hammer, J, which, the instant after a type has reached the proper position, strikes upon it, and presses against it a sheet or sheets of carbonized and writing-paper, held in contact between said hammer and the type-plate. Hammer J is constructed preferably of metal, and carries in a groove formed in its head,  $z$ , a small square pin,  $a^1$ , also preferably of metal, and faced with skin. The pin  $a^1$  is secured by the set-screw  $b^1$ , which serves to adjust the pin, so that by being caused to project more or less, its face may coincide vertically with the type-plate, the lateral adjustment of said hammer-face being effected by the screw  $d^1$ , which secures the hammer in any lateral position to which it may be turned on its stem. Hammer J works in cloth-lined holes,  $e^1$ , formed in projections in the bar L. The hammer is operated by the rod  $g^1$ , hinged on a centre wire in the grooved block  $a^2$ , fixed to its butt, and having a catch,  $b^2$ , at its other end. This catch engages an arm,  $c^2$ , projecting from the middle of the oscillating-rod M, which, when a key is depressed, retracts the hammer from the type-plate against the India-rubber spring  $a^3$ , and lets it slip when the key is depressed through its full movement. The arm  $c^2$  is so shaped as to have an eccentric movement, the moment when it pushes the rod  $g^1$  off the catch  $b^2$  being determined by the screw  $f^2$ , which passes through said rod, and impinges against the face of the arm  $c^2$ . A lead weight,  $f^3$ , or a suitable spring, causes the catch  $b^2$  to slip back to its position when the oscillating-rod M falls back to its place. The rod M works in bearings,  $k^1$ , and rests on projections  $r^1$  of the levers C, by which it is operated. The said India-rubber spring  $a^3$  acts on the rod  $g^1$ , by means of the movable tongue or lever  $g^2$ , against which the projection  $v^1$  is pressed when the hammer is retracted. The tongue  $g^2$  is stopped by the block  $s^1$ , which prevents the hammer from being pressed against the type-plate when stationary, the latter part of the movement of said hammer being accomplished by its impetus. Instead of operating the hammer by a spring, as described, it may be thrown against the plate directly, by the depression of a lever, after the manner of a piano-forte hammer. In this case, the rod corresponding to the "sticker" of a piano-forte, should be of such a length that the slow depression of a key will not carry the hammer quite in contact with the type-plate F, the latter part of the movement being accomplished by impetus, and said rod must also terminate, at its upper or lower end, in a spring of any convenient form, said arrangement being necessary to break the suddenness of the key-stroke, and allow the vibration of the plate, on reaching the common point, to subside before the stroke of the hammer.

In order to feed the paper during the progress of the writing, it is held in a clamp, O, formed of thin slips of wood, bound together by India-rubber cords,  $j^1$ , and opened by pressure on their margins,  $k^1$ . This clamp rests in forks  $m^1$  in the frame P, from which it may be readily removed for a fresh sheet of paper. Frame P slides in grooves in  $n^1$ , formed in the upper and lower sides of the frame Q. Frame P is moved from right to left by the square or triangular metal rod R, rotating in bearings formed in board B and the upper part of frame A', and furnished with a pulley, S, an escapement-wheel, T, and pinion,  $o^1$ . The pulley S slides freely on rod R, rotating with it, and is connected with frame P by the cords  $p^1$ . The rod R is rotated, and the frame P moved by means of the India-rubber spring  $u^1$ , attached at one end to a fixed hook, and at the other to a lever,  $a^2$ , furnished with a curved rack,  $b^2$ , geared with pinion  $o^1$ . The movement of the whole is regulated by the escapement-wheel T and crutch U. Crutch U is operated through the link  $c^2$  and arm  $d^2$ , by the oscillating-rod M, a complete oscillation of the pallets making the interval between two characters, which oscillation is effected by striking and releasing a key. When it is desired to cause the paper to move without an impression being made, it is only requisite to depress a key through a portion of its movement, the whole movement not being requisite to release a tooth of the escapement-wheel. To cause the frame P to return to its starting-point when a line has been completed, the two levers, Y and W, are employed. The lever W is furnished with an arm,  $h^3$ , connected by link  $i^2$  with bell-crank lever X, working in grooved block F. The lever X is connected by another link,  $j^2$ , with the lever  $k^2$ . The lever  $k^2$ , working on the vellum-hinge Z, supports at one end the stud  $m^2$ , in which the crutch U oscillates. While the escapement is in operation, the lever  $k^2$  is pressed by the spring  $n^2$  against the arm  $o^1$ , the screw  $p^2$  serving to adjust its distance from the escapement-wheel. When a line of writing has been finished, the lever W is depressed, and by the action of the arm  $h^3$ , link  $i^2$ , bell-crank lever X, and link  $j^2$ , the lever  $k^2$ , and with it the crutch and pallets, are withdrawn from the escapement-wheel. The escapement-wheel being thus freed, the lever Y is depressed, which, through the vertical link-rod  $q^2$ , operates the bell-crank lever  $r^2$ . The lever  $r^2$  moves the lever  $a^2$ , and the curved rack  $b^2$ , engaged with pinion  $o^1$ , reverses the movement of the rod R, and causes the frame P to return to the right-hand side of the frame Q. The distance between the lines is made by the lever W, in the same movement as that by which it frees the escapement-wheel. This it does by raising the link-rod  $s^2$ , lever  $t^2$ , and pawl  $w^2$ . The pawl is kept from falling into the rack  $v^2$ , affixed to frame Q, by the shoulder  $w^1$ , against which it is pressed by the India-rubber spring  $x^2$ . The elevation of lever  $t^2$  moves the pawl  $w^2$  forward, as well as upward, until it engages the rack  $v^2$ , when it moves the frame Q and the contained frame P the distance of a tooth, making the interval between two lines, the frame Q at the same time carrying up the pulley S. The frame Q slides in grooves,  $m^3$ , being retained at any height by friction applied by the button  $q^1$  and screw  $n^3$ , or by a suitable spring. On releasing the key controlling the lever W, the pawl  $w^2$  leaves the rack free, so that frame Q may be lowered at any stage of the writing.

The apparatus for bringing back the frame P for a new line, and for raising the frame Q, may be varied. An additional lever and key may be employed, and the escapement-wheel freed, the rod R reversed, and the frame Q elevated by separate-keys, without a material alteration in the construction and arrangement of parts. Also the pinion  $o^1$  may be placed at the upper end of rod R, and the rack-lever  $a^2$  at the top of the frame A', so that the bell-crank lever  $r^2$  and the lever  $t^2$  may work in the same centre.

Having thus fully described my invention, and the manner of operating the same—

1. I claim the oscillating-rods H I, constructed and operating substantially as and for the purpose set forth.
2. I claim the adjusting screws  $x$ , substantially as arranged, and for the purpose set forth.
3. I claim the rod G, the bell-crank lever K, links  $o$   $n$ , and India-rubber joints  $p$ , constructed, arranged, and operating substantially as described.
4. I claim the rod  $g^1$  and oscillating-rod M, tongue  $g^2$  and spring  $d^1$ , constructed, operated, and arranged substantially as and for the purpose set forth.
5. I claim the rod R, escapement-wheel T, crutch U, link  $c^2$ , and arm  $d^2$ , rod M, and pulley S, arranged and constructed substantially as and for the purpose described.
6. I claim the pinion  $o$ , lever  $a^2$ , and attached curved rack  $b^2$ , spring  $u^1$ , bell-crank lever  $r^2$ , and rod  $q^2$ , frame P and clamp  $o$ , constructed, arranged, combined, and operating substantially as and for the purpose set forth.
7. I claim the frame Q, sliding in grooves  $m^3$ , rack  $v^2$ , the lever  $t^2$ , link-rod  $s^2$ , pawl  $w^2$ , and lever W, constructed, arranged, and operating substantially as and for the purpose set forth.
8. I claim the lever  $k^2$ , spring  $n^2$ , link  $j^2$ , bell-crank lever X, link  $i^2$ , arm  $h^3$ , and lever W, or their equivalents, arranged, combined, and operating substantially as described.

JOHN PRATT

Witnesses:

HENRY GILBY,